

Fine Blasting Unit Gobi-2 (-3 / -4)



Gobi-2



Gobi-3



Gobi-4



USER MANUAL

Dear customer,

Thank you for choosing a product from the Wassermann range. Wassermann Dental-Maschinen incorporates the highest standards of quality and the latest technology. In order to enjoy maximum performance and years of trouble-free operation, please read this user manual carefully before you connect this device and start work, and operate the device according to the recommended guidelines. The operation safety and the functionality of this device can only be guaranteed if you follow both the general safety guidelines and the applying laws to prevent accidents as well as the precautions given in this user manual. We are not liable for any damages which occur due to inappropriate usage or faulty operation of this device.



Make sure that anyone using this device has read and understood this user manual.

Keep this user manual in a safe place where it can be referred to as required at any time.



The unit complies with the relevant EU guidelines.



The unit is subject to the EU guidelines 2012/19/EU (WEEE Directive).

Company address:

Wassermann Dental-Maschinen GmbH

Rudorffweg 15-17

21031 Hamburg, Germany

Phone : +49 (0)40 730 926 -20/ -24 Fax.: +49 (0)40 730 37 24

export@wassermann-dental.com

www.wassermann.hamburg

Contents

1 Features.....	4
2 Safety Symbols used in this Manual.....	5
3 Safety Guidelines.....	5
4 Responsibility for Operation or Damage.....	6
5 Application.....	6
6 Before Starting.....	6
6.1 Transport.....	6
6.2 Installation.....	7
6.3 Storage.....	7
7 Installation/ Start-up.....	8
7.1 Assembly Follow-up Kit.....	10
8 Operation.....	14
8.1 General Operating Instructions.....	14
9 Troubleshooting.....	15
10 Care and Maintenance.....	16
10.1 Cleaning.....	16
10.2 Maintenance.....	16
10.2.1 Sleeve Replacement.....	17
10.2.2 Screen Replacement.....	17
10.2.3 Conducting Hose Replacement.....	17
10.2.4 Lamp Replacement.....	18
10.2.5 Nozzle Replacement.....	18
10.2.6 Protection Filter Replacement.....	19
10.2.7 Water Separator.....	19
10.3 Warranty.....	20
10.4 Scope of Delivery/ Accessories.....	20
10.5 Spare Parts.....	21
10.6 Service Hotline 0049 (0)40 730 926 -20/ -24.....	21
10.7 Repairs.....	21
11 Technical Data.....	22
12 Disposing of the Unit.....	22
12.1 Information on Disposal for Countries within the EU.....	22
13 EU Declaration of Conformity.....	23

1 Features

This precision fine blasting unit of the Wassermann-brand offers you the highest quality and most advanced technology.

This 2-chamber-unit is perfect for blasting, roughing as well as blasting with specially fused alumina. The entire system is continuously under pressure and is therefore always ready for use. The relation between air and the blasting medium is set at the factory. It is determined by the size of the drillings. However, the discharge velocity can be varied by the built-in pressure reducer. The discharge velocity determines the outflowing amount of blasting media (while the relation is kept optimal and constant).

Even when switching on the unit again, you can use the quick-start- and quick-stop-function to begin blasting immediately. This is possible due to the crushing valve at the conducting hose.

This unit is equipped with a socket (power consumption: max 8 A).

- reliable and reasonably priced fine blasting units with 2 to 4 chambers
- quick foot-controlled start/stop function
- precise working pressure of 1–6 bar with pressure gauge control
- optimum illumination, protected fluorescent lamp
- special, particularly durable hoses
- convenient colour coding system
- comfortably to handle with ergonomically shaped handpieces
- hygienic changeable sleeves
- rapid ventilation of the blasting material containers for rapid re-filling and changing of blasting material
- possibility to connect to suction unit
- long durability, high flexibility
- specially coated protection screen for ideal visibility

2 Safety Symbols used in this Manual



Warning!

This is a warning of risk situations and dangers.

Failure to observe this warning could be life-threatening. These warnings has to be observed.



Information!

This symbol draws your attention to specific features that has to be observed.

3 Safety Guidelines

Configuring and operating this equipment requires **precise knowledge** and **observance** of the instructions in this **user manual**. The equipment is designed only for its intended application.



WARNING:

Servicing and repairs should be carried out only by authorised specialists.
Disconnect the power plug before starting any maintenance work.



Make sure that the equipment is connected to the correct power source.



Working is only allowed with the blasting chambers closed.



Please wear safety goggles!



Warning: Never connect to an oxygen bottle.

Risk of dust explosion.

4 Responsibility for Operation or Damage

The responsibility for operating the device lies exclusively with the owner or user if said device is incorrectly serviced, maintained or altered by persons not employed by an authorised dealer or if the device is used in a manner contrary to its specified purpose.

The unit has to be maintained and operated in accordance with this user manual.

Wassermann Dental-Maschinen GmbH is not responsible for damage arising from the **nonobservance** of these instructions.

Warranty and responsibility provisions contained in the sales and supply conditions of Wassermann Dental-Maschinen GmbH are not extended by these instructions.

5 Application

This 2-chamber-blasting unit is designed for blasting, roughing as well as blasting with specially fused alumina.

Only use the device for this type of application.

6 Before Starting

6.1 Transport

Before transporting the unit, ensure that it has been unplugged from the power socket. Make sure that it is packed correctly in order to avoid accidental damage.



Be sure to check for any transport damage when unpacking the goods. Note down any damage if found.

6.2 Installation

- Open the box, remove the packing materials, and carefully lift out the device and accessories.
- Avoid lifting the unit on the mounting bracket of the air control unit because it could bend or break.
- Avoid lifting the unit on the additional tanks because they are only suspended. There is a risk that you break the additional tanks and the unit is dropped.
- The device has to stand horizontally on a steady and even surface.
- Check the included accessories.



Install the device in a place where it will not block the working area and the functionality (take the dimensions into account).



Do not install the unit outdoors or in places without proper ventilation.

Before start-up, be sure the device reaches room temperature.

6.3 Storage

The unit location is very important when it comes to workplace safety, even if it is only to be set up there for a short period. The room should be dry, well ventilated and vibration-free. An even temperature and wooden supports also help. The unit should not be stored or set up outdoors. If the unit is to be stored for an extended period, protect it from moisture and dust.

7 Installation/ Start-up



Before starting the unit, connect up the following:

- Prepare a compressed air connection.
- Furthermore an external dust-extractor should be connected.
- The connectors are accessible from the back.
- **Finally**, insert the power plug into the socket, making sure that the mains and the unit operate on the same voltage.



Before using the unit, let it stand with open chambers until it has reached room temperature.

- It is absolutely necessary to switch the unit off before filling.
- The chambers can first be screwed on when they are completely pressureless. Press the red knob of the screwed-on cover at the right side until no outflowing air can be heard.



All chambers are vented by pressing the according air vent knob.

- The chamber at the right (red) will always be filled with 110-250 my material.
- The chamber at the left (blue) will always be filled with 50-110 my material.
- If your unit has additional tanks you can individually choose the blasting material. If required please ask for add-on kit.
- The chambers are only allowed to be filled up to 4 cm from the upper chamber edge. The filling quantity shall not exceed the inside of the container located mark.



Before setting on the containers you have to assure that the threads and sealing surfaces are free of blasting media grains.

- Screw on the screwed-on cover properly in accordance with the colour indicator. When all chambers have been screwed on the unit is ready for use and can be switched on.
- Insert the power plug firmly into the power outlet (220-240 V / 50/60 Hz).
- Switch on the main switch (green toggle switch).
- Set the pressure reducer to working pressure. There must be no hissing noise. Otherwise, please retighten the screwed-on cover by hand.

7.1 Assembly Follow-up Kit

Please carry out the following preparatory measures:

- Before you start the assembly check that the follow-up kit has been delivered complete.
- Unplug the Gobi-2 from its socket so that the mains supply is disconnected.
- Remove your pressurised air connection to a safe distance and make sure that the Gobi-2 is no longer “under pressure”.
- In the work room remove the plug for the lead through of the steel stylus: left for the left-hand add-on tank (yellow); right for the right-hand add-on tank (green). **Figure 1**
- On the left-hand add-on tank loosen the lower screw of the electro-cover.

Only loosen, do not remove! Figure 2

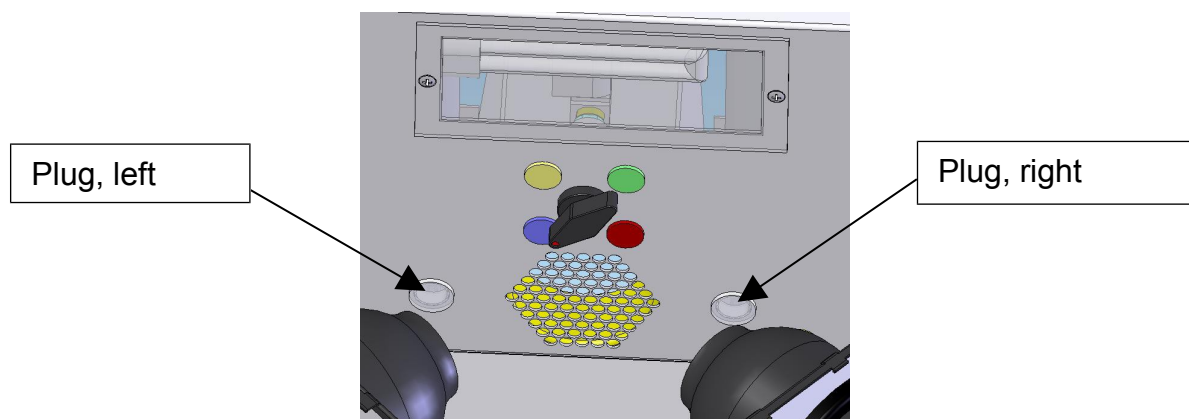

Fig. 1

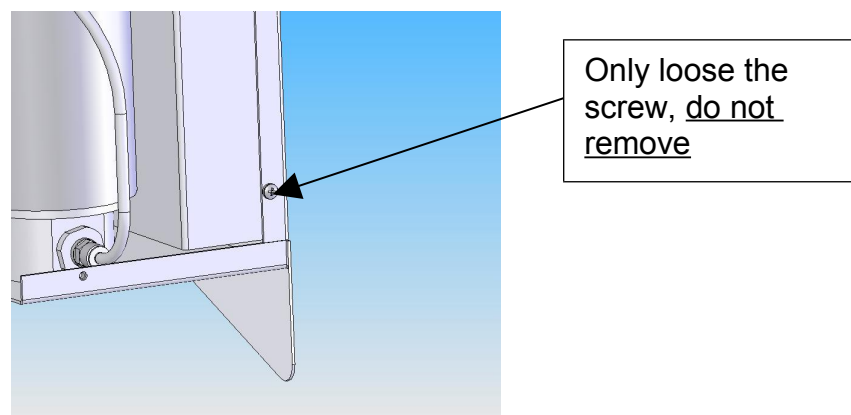

Fig. 2

Now you are ready to begin the following assembly tasks:

- Screw the screws delivered with the add-on tank loosely into position in the casing of the Gobi-2. **Figure 3 and 4**
- Now hook in the add-on tank onto the screw. Please take special care to see that on all three of the hook-in drillings the screw heads are flush. The “wing” of the tank retaining plate must be pushed underneath the screw which is inserted in a sideways position. **Figure 5**

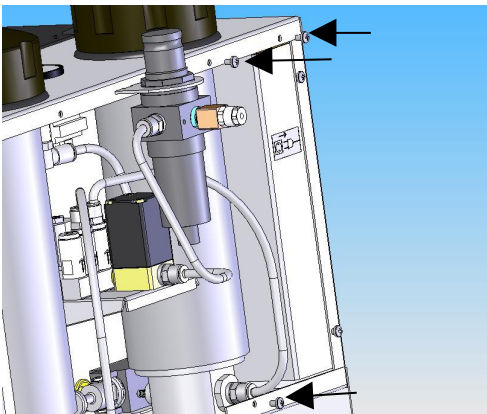

Fig. 3

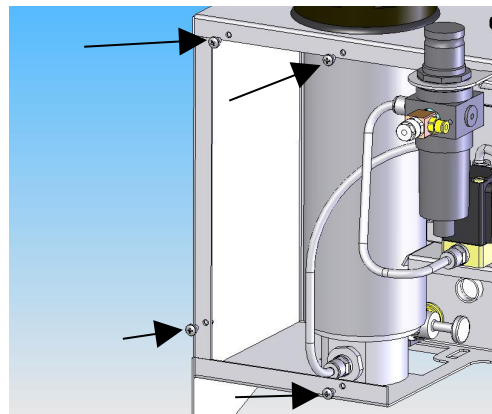

Fig. 4

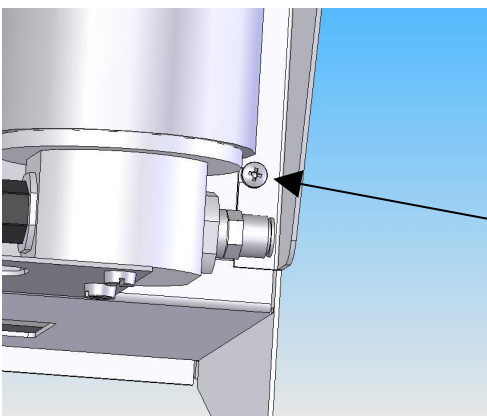

Fig. 5

The “wing” of the tank retaining plate must be pushed underneath the screw.

- All accessible screws are now to be screwed in tight.
- Push the steel stylus into the work cabin through the hole in the casing.
- Close the hole with the lead-through grommet thereby fixing the steel stylus. Take care to lay the steel hose with a slight curve and don't let it buckle.
- Through the work cabin remove the indicator window and take out the lamp.
- In each case remove the appropriate connection plug by pressing down the ring of the plug screw-joint, at the same time pulling on the connection plug. **Figure 6.**

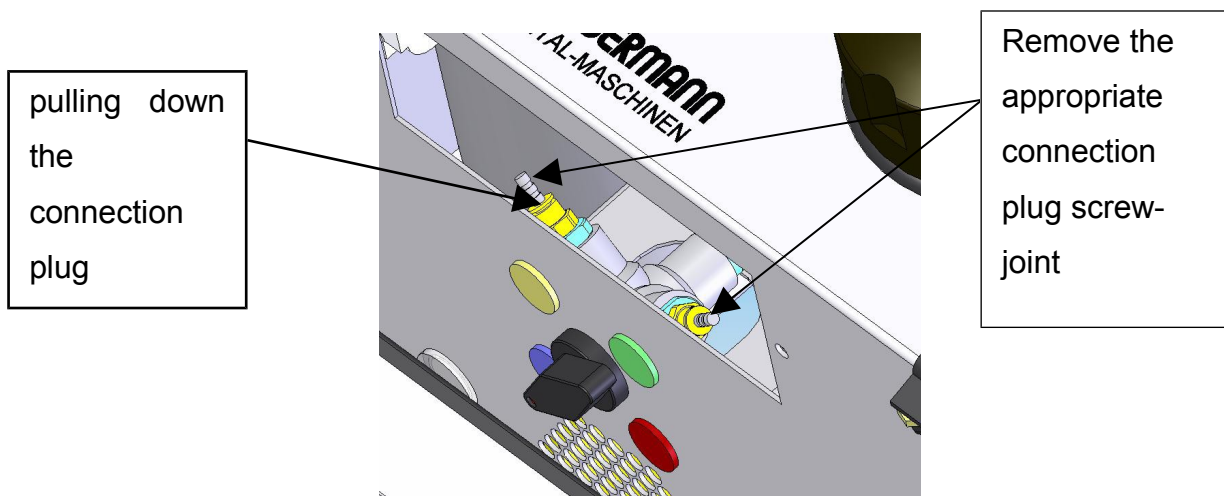

Fig. 6

- With the help of the PA-hose (320023) connect the ball cock with the squeezing valve.
- Fix the lamp back in and then the cover.
- On the back remove the connection plug on the air current unit, there also by pressing down the ring of the plug screw-joint and at the same time pulling on the connection plug. Tip: try pressing the ring down with the assistance of a slotted screwdriver. **Figure 7**

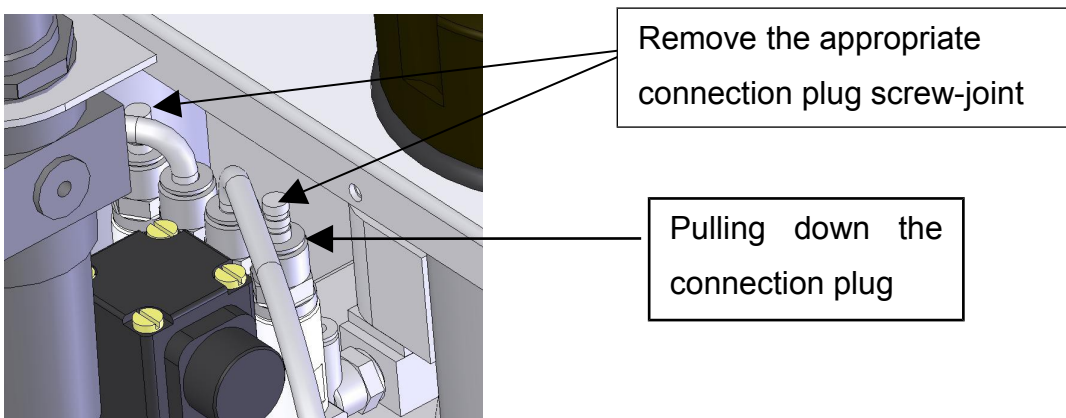

Fig. 7

- With the help of the PU-hose (320054) connect the air current unit with the blasting material container.
- Please take care that the blasting hoses run along under the sieve grille and that the blasting protector is mounted.

8 Operation

8.1 General Operating Instructions

All instructions for using the unit, whether in verbal or written form, are based on our own experience and experimentation and can only be regarded as guidelines.

1. Turn on main switch (green toggle switch).
2. Set the working pressure at the desired level on the reducing valve (at least 2.3 bar at most 6 bar).
3. Designate the blasting material container by using the selection switch built-in in the work room. If you do not possess any add-on tanks, then the green and yellow settings will not perform any functions. Do NOT select them, since this can lead to complications.
4. According to the colour selected, take the appropriate stylus in your hand.
5. Trigger the blasting process with the foot control.



Due to the operating condition, the amount of blasting media flow may change when the blasting media amount decreases.

By shortly tilting the unit it is possible to continue working for a short time. However, this is an indication that you have to refill blasting media.



Female connector power consumption max: 8 A

9 Troubleshooting

Fault	Cause	Solution
Irregular flow of blasting material	Too little blasting material in container	Re-fill the container
	Jet on stylus too small	Use larger jet
	Blasting material is moist	Use blasting material of correct dryness
No flow of blasting material	Container empty	Re-fill the container
	Main jet and/or steel hose blocked	Use recommended, dry blasting material. Unscrew jet on the stylus. Trigger blasting process. Blasting material should flow. If necessary, briefly hold the hose closed to build up some counter-pressure.
	Wrong selection of colour circuit setting	Please switch to the correct colour circuit setting
	Ancillary jet blocked	Refer above
	Too little pressurised air < 3 bar	Increase pressure
Decreasing and/or to low blasting pressure	Filter blocked and/or buckled closed	Change filter element



If the above recommendations do not solve the problem, contact your dental depot or our service department.

Remarks:

Obstructions normally occur from soiled or lumpy blasting medium. If the sand draws moisture, check the condensator.

Most obstructions occur inside the nozzle. To remove such obstructions unscrew the nozzle and clean it. In general this would be sufficient to make the stuck grains come loose. If the obstruction persists, use a needle and push it through the hole.

10 Care and Maintenance

10.1 Cleaning



Disconnect the power plug before starting any maintenance work.

The identification plate has always to be kept in easily legible condition and has not to be removed.



Remove external dirt from time to time with some form of cold cleaner.

Use only cold cleaners to avoid damaging the paintwork or removing the lettering.

The equipment should be cleaned at regular intervals to ensure trouble-free operation.

It requires only normal cleaning (sponge, damp cloth, mild detergent) and no further chemical additives.

- The inside of the chambers and the protection screens can be cleaned with compressed air. Fine-dust will be sucked out by the dust-extractor.
- Never use strong and abrasive solvents for cleaning the screens.
- Coarse-grained sand, which cannot be sucked out by the dust-extractor can be removed through the discharge opening.

10.2 Maintenance

This unit does not require any special maintenance. Just make sure that the device is kept clean.

However, after using the unit a certain time, it will be necessary to replace some parts.

Please take care of the following parts:

10.2.1 Sleeve Replacement

Sleeves can also be replaced with gloves. The procedure is the same.

- Loosen the connector with pliers and unscrew the throughgrip (4 screws).
- Pull off the old sleeve and put on the new one so that it completely covers the opening.
- Attach the new connector. Take care that the closing of the connector is placed inside the notch of the opening.
- Tighten the opening.

10.2.2 Screen Replacement

- Open the flap and loosen the five knurled nuts.
- Remove the guide rail
- Fold the screen to the front and pull it out. Please take care of the spacer reels.
- Replace the screen and reassemble everything in reverse order.

10.2.3 Conducting Hose Replacement

Before changing, the mains plug must be disconnected and the pressurised air connection detached.

The pressure of all the tanks must be released (cf. Installation / Start-up).

- Take sieve unit out of the chamber.
- Lay the appliance on its side so that you have access to the bottom of the appliance.
- In order to detach from the tank the blasting material hose in question, loosen the black nut with a no. 17 spanner, then take it, and subsequently the hose too, off.
- Pull and/or lever the silver handle on the squeezing valve, with the other hand pulling the hose through the through-put and into the interior.
- Remove hose protection.

- In principle the installation takes place exactly in the reverse manner. The hose is pushed from the interior of the chamber through the hole on the squeezing valve, led through it again and pushed onto the nipple of the tank (don't forget the nut and the plastic cap!). Before the nut is tightened the fabric must be completely pulled over the rubber. Should this be difficult to achieve then push the fabric outwards from the stylus right to the end until enough fabric is available.
- The nut can then be completely tightened (not with force! Don't overturn it!).
- The small hose is only to be pushed in up to the squeezing valve. The hose should be sandwiched in between both of the styluses. It serves as a protection for the blasting hose.
- Put the appliance back in an upright position and re-install the sieve grille. Please take care that the blasting hoses run along under the sieve grille and that the hose protector is mounted.

10.2.4 Lamp Replacement

Before changing it you must pull out the mains plug. The lamp is behind the indicator window.

- Loosen knurled nuts and take off the indicator window.
- Pull the lamp towards the right out of its socket and in re-placing make sure that the new lamp fits correctly back into the socket.
- Put back the indicator window and tighten the screws.

10.2.5 Nozzle Replacement

Take care that the nozzle always corresponds to the size of the used blasting medium. The replacement is very easy. Simply unscrew the old nozzle and screw on a new one.

Important: Before setting up a new nozzle, shortly operate the unit and blow away old blasting medium which may remain inside the hose.

10.2.6 Protection Filter Replacement

After some time of usage the filter inlet may become clogged. This filter is located in an aluminum housing (transition piece) directly at the blasting material container.

- Loose the nut at the container with a 17mm wrench.
- Press down lightly the ring inside the connection and remove the hose
- Unscrew and remove the connection.
- Unscrew and remove the transition piece from the blasting material container with the help of suitable tools.
- Change the transition piece and screw it back into the blasting material container.
- Screw the connection.
- Reconnect the air tube.

10.2.7 Water Separator

A water separator, that absorbs any condensation coming out of the compressor, is situated at the back of the unit. It must be checked regularly and at the latest when the max. level is reached, it must be emptied. To do this, press the yellow discharge lever up so that the water can flow into the container you have placed under the unit.

Remarks:

Obstructions normally occur from soiled or lumpy blasting medium. If the sand draws moisture, check the condensator.

Most obstructions occur inside the nozzle. To remove such obstructions unscrew the nozzle and clean it. In general this would be sufficient to make the stuck grains come loose. If the obstruction persists, use a needle and push it through the hole.

10.3 Warranty



The warranty period for our equipment is 12 months. If faults occur within the warranty period, contact your dental depot or get in touch directly with our service department.

Your equipment should only be operated in perfect condition. If faults occur which could harm operators or third parties, the unit should not be used until it has been fixed.

This warranty does not cover damage caused by improper use, external mechanical causes, transport damage or interference with the unit by unauthorized persons.

10.4 Scope of Delivery/ Accessories

Incl. in delivery	Item no.:
Compressed air hose, PVC hose Ø 8x6 textile (blue) 2 m	320026
Supply line	592012
Gobi-2 incl. 2 fine blasting nozzles, 0.8 (blue), 1.2 (red)	190896
Gobi-3 incl. 3 fine blasting nozzles, 0.8 (blue), 1.2 (red) and optionally additional tank, left with fine blasting nozzle 0.6 (yellow) or 0.8 (green)	190896 + item no. additional tank
Gobi-4 incl. 4 fine blasting nozzles, 0.8 (blue), 1.2 (red) and additional tank, left with fine blasting nozzle 0.6 (yellow) and additional tank, right with fine blasting nozzle 0.8 (green)	190896 + 190800 + 190802

Accessories	Item no.:
Compressed air hose, PVC hose Ø 8x6 textile (blue) per meter	320026
Additional tank, left with fine blasting nozzle 0.6 mm (yellow)	190800
Additional tank, right with fine blasting nozzle 0.8 mm (green)	190802
Spare fine blasting nozzle 0.6 mm	190550
Spare fine blasting nozzle 0.8 mm	190551
Spare fine blasting nozzle 1.2 mm	190552
Spare sleeve, per piece	190175



We recommend the use of **Wassermann blasting materials** and our **low-pressure suction units SG-10, SG-1/1 and SG-1/2 D** with a long-life brushless motor and an extra large micro fine dust filterbag.

Summary nozzles and blasting materials

Item no.	Name of the item	Blasting material
190550	Fine blasting nozzle 0,6 mm	50 my
190551	Fine blasting nozzle 0,8 mm	110/125 my + 50 my Glass beads
190552	Fine blasting nozzle 1,2 mm	250 my + 110 my Glass beads
190565	Nozzle for blasting material container 2,0 mm (for 1,2 mm blasting nozzle)	> 110 my
190566	Nozzle for blasting material container 1,4 mm (for 0,6 / 0,8 mm blasting nozzle)	< 110 my

10.5 Spare Parts

If necessary please contact our service hotline phone.

10.6 Service Hotline 0049 (0)40 730 926 -20/ -24

10.7 Repairs



Servicing or repairs to the unit has only to be carried out by qualified technicians. Only original spare parts are to be used. Responsibility for the product is voided if unauthorised persons alter it or if inappropriate components are installed.

11 Technical Data

Gobi 2	Item no.: 190896
Voltage	220–240 V / 50/60 Hz
Power consumption	0.2 A
Female connector power consumption max.	8 A
Output	50 W
W x H x D	430 x 350 x 530 mm
Weight	17.5 kg
Tank capacity	800 cm ³ = 1.2 kg
Compressed air connection	3–6 bar
Working pressure	1–6 bar
Extractor nozzle	75 mm

Other voltages on request.

The noise level of the unit amounts to ≤ 70 dB (A).



Technical changes reserved.

12 Disposing of the Unit

The unit has to be disposed by an authorized recycling operation. The selected company has to be informed of all possibly health-hazardous residues in the unit.

12.1 Information on Disposal for Countries within the EU



To conserve and protect the environment, prevent environmental pollution and improve the recycling of raw materials, the European Commission adopted a directive that requires the manufacturer to accept the return of electrical and electronic units for proper disposal or recycling.

Within the European Union units with this symbol should not therefore be disposed of in unsorted domestic waste.

For more information regarding proper disposal please apply at your local authorities.

13 EU Declaration of Conformity

in accordance with 2014/35/EU (Low Voltage Directive) and 2014/30/EU (Electromagnetic Compatibility Directive) and 2006/42/EC (Machinery Directive) and 2011/65/EU (RoHS Directive)

Manufacturer:	W A S S E R M A N N Dental-Maschinen GmbH Rudorffweg 15-17 21031 Hamburg Germany	Product description:	Fine Blasting Unit for dental applications
Model:	GOBI 2 with 2 blasting material containers GOBI 3 with 3 blasting material containers*/** GOBI 4 with 4 blasting material containers*&** *additional tank right (Item no. 190802) **additional tank left (Item no. 190800)	Item no.	190896
Applicable standards:	DIN EN 61010-1 DIN EN 61000-6-3 DIN EN 61000-6-1 DIN 45635-1 DIN EN 60335-1		

Hiermit wird bestätigt, dass die oben bezeichnete Maschine den genannten EU-Richtlinien entspricht. Diese Erklärung wird ungültig, falls die Maschine ohne unsere Zustimmung verändert wird.

This is to confirm that the above mentioned machine complies with the described EU guidelines. This declaration becomes invalid if the machine is modified without our approval.

Cette machine est conforme aux normes en vigueur d'Union européenne. Cet avis est nul et non avenant si cette machine est modifiée sans notre accord.

Esta máquina, anteriormente mencionada, cumple con los límites requeridos por el reglamento UE. Ahora bien, esta declaración quedará invalidada en caso de realizar modificaciones al aparato sin nuestra aprobación.

Hiermee wordt bevestigd dat bovengenoemde machine voldoet aan de voorgeschreven EU normen. Deze verklaring verliest geldigheid als er zonder onze uitdrukkelijke toestemming wijzigen aan de machine worden aangebracht.

Place, date: Hamburg, 2017-07-14

Company stamp:



Signature: _____
Wilfried Wassermann
(Managing Director)



Wassermann Dental-Maschinen GmbH
Rudorffweg 15-17 · 21031 Hamburg · Germany
Phone: +49 (0)40 730 926-0 · Fax: +49 (0)40 730 37 24
info@wassermann-dental.com · www.wassermann.hamburg