

# Steam Cleaner Wasi-Steam Classic



USER MANUAL

**Dear customer,**

Thank you for choosing a product from the Wassermann range. Wassermann Dental-Maschinen incorporates the highest standards of quality and the latest technology. In order to enjoy maximum performance and years of trouble-free operation, please read this user manual carefully before you connect this device and start work, and operate the device according to the recommended guidelines. The operation safety and the functionality of this device can only be guaranteed if you follow both the general safety guidelines and the applying laws to prevent accidents as well as the precautions given in this user manual. We are not liable for any damages which occur due to inappropriate usage or faulty operation of this device.



Make sure that anyone using this device has read and understood this user manual.

Keep this user manual in a safe place where it can be referred to as required at any time.

 The unit complies with the relevant EU guidelines.



The unit is subject to the EU guidelines 2012/19/EU (WEEE Directive).

**Company address:**

Wassermann Dental-Maschinen GmbH

Rudorffweg 15-17

21031 Hamburg, Germany

Phone : +49 (0)40 730 926 -20/ -24 Fax.: +49 (0)40 730 37 24

export@wassermann-dental.com

www.wassermann.hamburg

www.facebook.com/WassermannDentalmaschinen

## Contents

1 Features.....	4
2 Safety Symbols used in this Manual.....	4
3 Safety Guidelines.....	4
4 Responsibility for Operation or Damage.....	6
4.1 Warranty.....	6
5 Application.....	6
6 Before Starting.....	7
6.1 Transport.....	7
6.2 Installation.....	7
6.3 Storage.....	8
6.4 Mounting Instruction Fastening Set for Wall Mounting Wasi-Steam Classic.....	8
7 Start-up/ Installation.....	12
8 Operation.....	14
8.1 General Operating Instructions.....	14
8.1.1 Refill.....	15
9 Troubleshooting.....	16
10 Care and Maintenance.....	17
10.1 Cleaning.....	17
10.2 Maintenance.....	18
10.2.1 Decalcification.....	18
10.3 Repairs.....	18
10.4 Spare Parts.....	19
10.5 Service Hotline 0049 (0)40 730 926 -20/ -24.....	19
10.6 Scope of Delivery/ Accessories.....	19
11 Technical Data.....	19
12 Disposing of the Unit.....	20
12.1 Information on Disposal for Countries within the EU.....	20
13 EU Declaration of Conformity.....	21

## 1 Features

- Manual filling so the location can be flexibly selected
- Operation with distilled / softened water is possible and is recommended
- Comfortable application through single-handed operation of the jet gun
- Variable working pressure, variable up to 5 bar
- Short heat-up phase through 1,200 Watt-special steel heating
- Wall mounting possible

## 2 Safety Symbols used in this Manual



### **Warning!**

This is a warning of risk situations and dangers.

Failure to observe this warning could be life-threatening. These warnings has to be observed.



### **Information!**

This symbol draws your attention to specific features that has to be observed.

## 3 Safety Guidelines

Configuring and operating this equipment requires ***precise knowledge*** and ***observance*** of the instructions in this ***user manual***. The equipment is designed only for its intended application.



### **WARNING:**

Servicing and repairs should be carried out only by authorised specialists.

Disconnect the power plug before starting any maintenance work.



Make sure that the equipment is connected to the correct power source.



- Never touch the steam gun directly at the nozzle – **risk of scalding!**
  
- When refilling with water\* it is imperative to note point **8 (Operation)** of this user manual – **risk of scalding!**  
\*Operation with distilled / softened water is possible and is recommended
  
- Never point the steam gun at people (living beings) – **risk of injury!**
  
- The device has several safety features:
  - Pushbutton switch 5 bar,
  - Thermo-safety switch with manual reset 165° degrees Celsius
  - Adjustable thermostat max. 180° degrees Celsius
  - Safety valve 7 bar
  
- The device can be filled manually, e.g. by means of a beaker, funnel, or the like. The device must not be filled with pressure and or be attached to a tap.

## 4 Responsibility for Operation or Damage

The responsibility for operating the device lies exclusively with the owner or user if said device is incorrectly serviced, maintained or altered by persons not employed by an authorised dealer or if the device is used in a manner contrary to its specified purpose. The unit has to be maintained and operated in accordance with this user manual. Wassermann Dental-Maschinen GmbH is not responsible for damage arising from the **nonobservance** of these instructions.

Warranty and responsibility provisions contained in the sales and supply conditions of Wassermann Dental-Maschinen GmbH are not extended by these instructions.

### 4.1 Warranty



The warranty period for our equipment is 12 months. If faults occur within the warranty period, contact your dental depot or get in touch directly with our service department.

Your equipment should only be operated in perfect condition. If faults occur which could harm operators or third parties, the unit should not be used until it has been fixed.

This warranty does not cover damage caused by improper use, external mechanical causes, transport damage or interference with the unit by unauthorized persons.

## 5 Application

Because of its variable work pressure of up to 5 bar it offers the user a gentle but quick and thorough cleaning of all small parts in the dental laboratory.

Only use the device for this type of application.

## 6 Before Starting

### 6.1 Transport

Before transporting the unit, ensure that it has been unplugged from the power socket. Make sure that it is packed correctly in order to avoid accidental damage.



Be sure to check for any transport damage when unpacking the goods. Note down any damage if found.

### 6.2 Installation

Open the box, remove the packing materials, and carefully lift out the device and accessories. Check the included accessories.

The device must stand on a steady and even surface or may be mounted to a stable wall by means of the mounting kit. If mounting the unit on the wall, make sure that the wall is strong enough to take the weight.

See 6.4 Mounting instructions fastening set for wall mounting Wasi-Steam Classic.



Install the device in a place where it will not block the working area and the functionality (take the dimensions into account).

Please see that the louvres are not set because air circulation (heat flow) is absolutely necessary.



Do not install the unit outdoors or in places without proper ventilation.

Before start-up, be sure the device reaches room temperature.

### 6.3 Storage

If the unit is to be stored for an extended period, protect it from moisture and dust.

The unit location is very important when it comes to workplace safety, even if it is only to be set up there for a short period. The room should be dry, well ventilated and vibration-free. An even temperature and wooden supports also help.

The unit should not be stored or set up outdoors.

### 6.4 Mounting Instruction Fastening Set for Wall Mounting Wasi-Steam Classic

Please check the included accessories:

<b>Incl. in delivery item.-no. 174358 fastening set Wasi-Steam Classic</b>	
<b>Quantity</b>	<b>Name</b>
1	Securing bracket
1	Phillips head screw M 4x8
1	Washer D 4,3
1	Serrated washer D 4,3
1	Slotted screw 4 x 16
2	Slotted screw 6 x 50
2	Screw anchor S8
1	Screw anchor S5



**Mounting instruction:**

Please drill the holes as indicated in the following drilling template. Please make sure before that the wall is really suitable for mounting a device (aerated concrete walls and drywall are problematic).

Drilling template

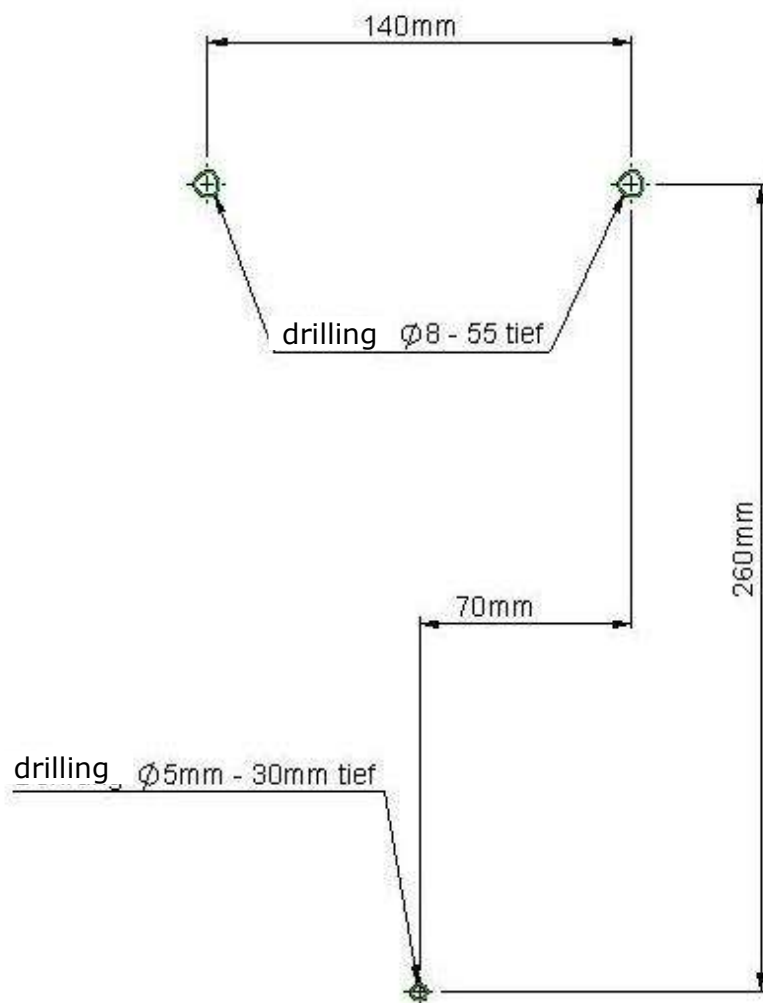

Secure the enclosed screw anchors as shown in Figure 1.

Screw the 6x50 screws into the two upper holes; keep a distance of 6-7 mm to the wall!

(Figure 2)

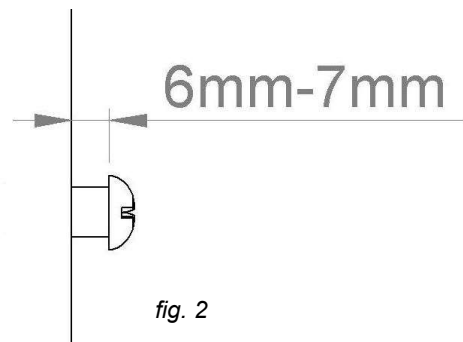
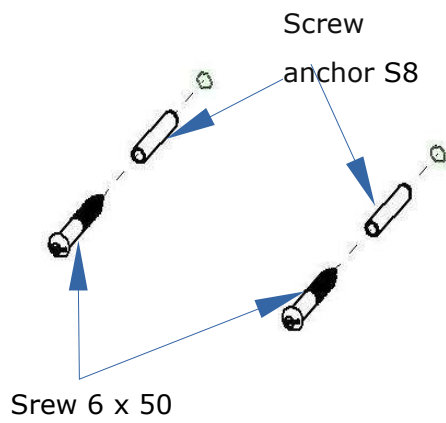

fig. 2

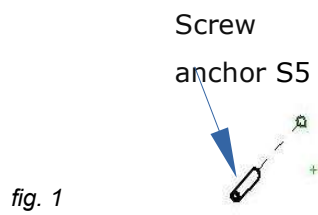

fig. 1

Screw the securing bracket to the Wasi-Steam Classic as shown in Figure 3.

Do not yet fully tighten the Phillips head screw, however – you still need to be able to move the securing bracket.

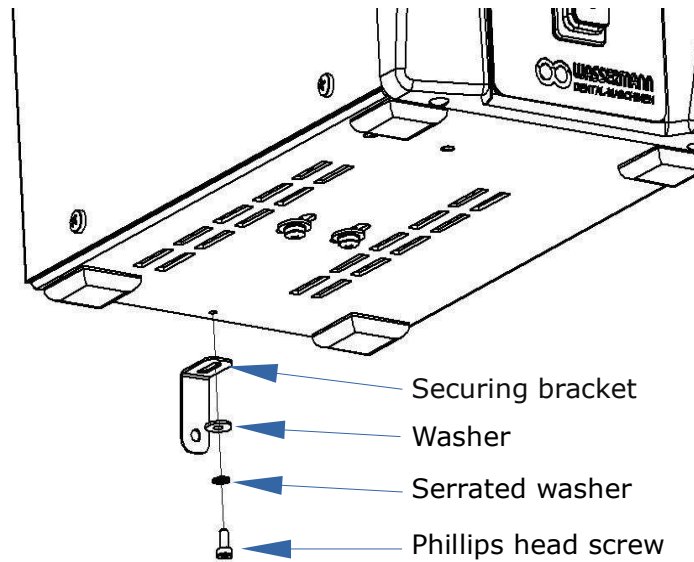
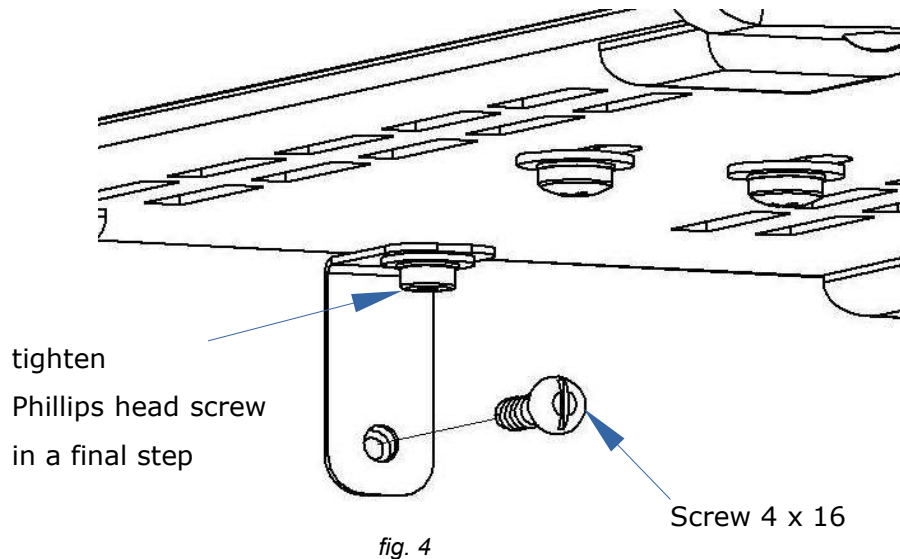

fig. 3

Carefully hook in the device. Check, whether the device hangs loosely (i.e. moving back and forth on the screws). If this is the case tighten the 6x50 screws until the device hangs securely.

Finally tighten the securing bracket. First at the wall, then tighten the screw on the device itself. (Figure 4)



## 7 Start-up/ Installation



Before you use the steam cleaner, please put on heat-resistant gloves and wear safety goggles.



Switch the unit off if it will not be used for an extended period.

**Note:** Optimal and fast pressurization is carried out only if the adjusting knob is in the "max." position, since the heater with this is activated via a push button switch, i.e. immediately at the start of every blasting action. In case of the pressure choice options (1-4), the heater is activated via a thermostat, i.e. even in case of a massive decrease in pressure it may take several minutes until the heater is activated due to residual heat of the container for example. Therefore this setting is preferable only in case of occasional work.



**Please note the details on the equipment stickers!!**

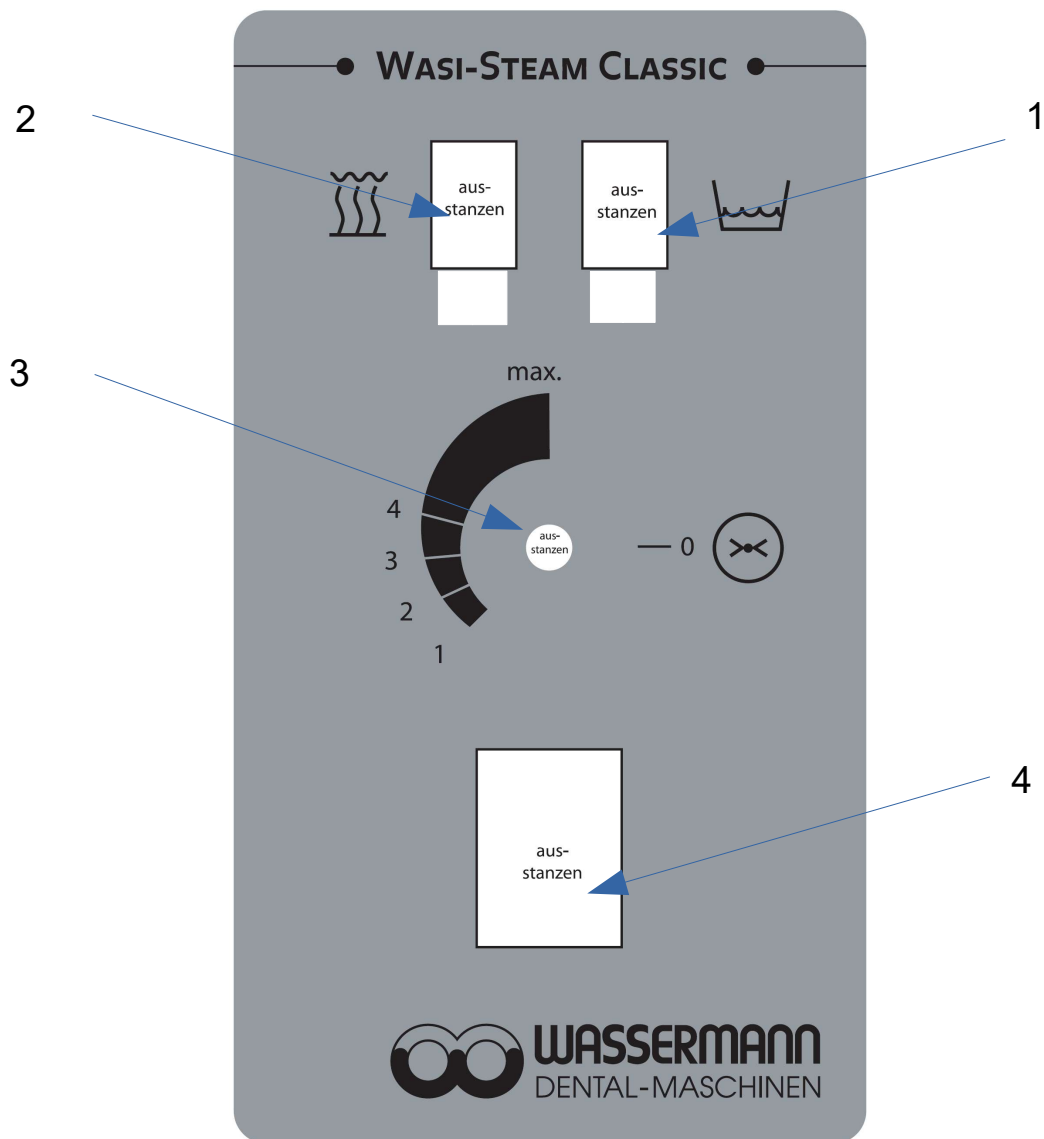

- 1 = light red (low water)**
- 2 = light green (heating operation)**
- 3 = controller steam quantity (1 – 5 bar)**
- 4 = main switch (unit on / out)**

- Open the screw top of the container carefully while pressing down the screw top
- Fill with at most 2 litres of water
- Operation with distilled / softened water is possible and is recommended
- Tighten container screw top sturdily again (hand-screwed)
- Connect power plug
- Switch on main switch (4)
- Choose pressure range from 1 – 5 according to the scale or choose max. with adjusting knob (3)
- **Heat-up phase** approx. 30 minutes (full container).

Briefly deaerate the device after approx. 15 minutes by operating the steam gun.

If the heating light (2) turns off, the device is ready for use. Now steam blasting via the gun is possible by operating the pushbutton until the temperature delimiter activates (button under black cap on the right side of the device) and the red light (1) lights up.

Then proceed by referring to point **8.1.1 "refill water"**).

## 8 Operation

### 8.1 General Operating Instructions

All instructions for using the unit, whether in verbal or written form, are based on our own experience and experimentation and can only be regarded as guidelines.



**To avoid an unintentional interruption of use (cooling down period approx. 45 min.), the device should be refilled every morning in a cold state (take fill level into account, or else the container will be overfilled).**



**Note: Do not refill more than 2 litres of water, if the red light (water shortage) lights up (otherwise the container will be overfilled).  
Operation with distilled / softened water is possible and is recommended .**



### 8.1.1 Refill

- After the red light (1) lights up, wait approx. 45 min. (**cooling down period**) until you refill again, or else there is a **risk of scalding** as long as the temperature remains above 100°C.
- Container must be **pressureless**; produce a pressure balance via the jet nozzle by operating the steam gun.
- Only now open the screw top of the container carefully while pressing down the screw top.
- Refill water (**2 litres at most**).
- Operation with distilled / softened water is possible and is recommended.
- Fully tighten the screw top of the container again (hand-screwed).
- Switch on the temperature delimiter (button under black cap on the right side of device) again as follows; first unscrew the black cap, then push in the pushbutton, the red light (1) goes out and the device heats up to the adjusted pressure. Finally, screw the black cap back on.
- Heat-up phase (see p. 14).
- Operational; i.e. steam blasting via the gun by operating the pushbutton is possible until the temperature delimiter activates again and the red light (1) comes on.

## 9 Troubleshooting

Fault	Cause	Solution
The red light (low water) lights up and the heating turns off	This is a safety feature of the steamer: Thermo-safety switch (temperature delimiter 165°C) with manual reset	Please see page 14/15.
No function, only the main switch lights up	Devise fuse faulty	Replace fuse and investigate cause; call service if necessary.
Steam escapes from device	Safety valve has opened because pressure switch is faulty	Turn off the device immediately (unplug power plug) and call service.
Hot water leaks from the nozzle instead of steam	Container is overfilled with water	Operate gun until only steam escapes.
Lower amount of steam than usual at max. heating	Nozzle of the steam gun is clogged or the water level in the container has reached the minimum level	Unscrew nozzle from gun and examine for passage ( <u>caution risk of scalding!!</u> ) or refill water (do not overfill!!). Operation with <u>distilled / softened</u> water is possible and is recommended.
Insufficient pressure build-up	Tank seal is still loose or O-ring is faulty	Check or replace tank seal.
No pressure in boiler	Container empty but red light or thermo switch faulty or container not empty but heater or heating regulator faulty	Check water level, refill if necessary and check the thermo switch button. If still no function, call service. Operation with <u>distilled / softened</u> water is possible and is recommended.
No steam when operating the pushbutton	Solenoid valve faulty or clogged	When operating the gun's pushbutton, a "clicking sound" is heard from the solenoid valve. If this is the case the problem could be resolved by cleaning the valve. Otherwise call service.



If the above recommendations do not solve the problem, contact your dental depot or our service department.



## 10 Care and Maintenance

### 10.1 Cleaning



Disconnect the power plug before starting any maintenance work.

The identification plate has always to be kept in easily legible condition and has not to be removed.



Remove external dirt from time to time with some form of cold cleaner.

Use only cold cleaners to avoid damaging the paintwork or removing the lettering.

The equipment should be cleaned at regular intervals to ensure trouble-free operation.

It requires only normal cleaning (sponge, damp cloth, mild detergent) and no further chemical additives.



Please see 10.2.1 „**Decalcification**“

## 10.2 Maintenance

The Wasi-Steam Classic should, depending on frequency of use, but at least twice a year, be decalcified in accordance with the following instructions. Depending on water hardness a more frequent decalcification could be required. Operation with distilled / softened water is possible and is recommended. As a basic principle, the device must always be kept clean.

### 10.2.1 Decalcification

- Turn off the main switch and unplug the power plug
- Empty / pour out container in cold state
- Mix approx. 50 cc lime scale remover with 2 litres of water and fill into the device (depending on lime content, the ratio can be increased)
- Heating regulator must be set to less than 1 bar
- Close tank cap
- Switch on the device and let it heat up briefly until the green light goes out
- Turn off the device and allow the lime scale remover to react for approx 8 hours (lime remover should not react longer than 12 hours)
- Pour out the solution and rinse with clear water (approx. 1 litre) at least two times by shaking the device
- Refill only maximal 2 litres of water (otherwise the tank could overflow)
- Operation with distilled / softened water is possible and is recommended
- The steam cleaner is now ready for operation

## 10.3 Repairs



Servicing or repairs to the unit has only to be carried out by qualified technicians. Only original spare parts are to be used. Responsibility for the product is voided if unauthorised persons alter it or if inappropriate components are installed.

## 10.4 Spare Parts

If necessary please contact our service hotline phone.

## 10.5 Service Hotline 0049 (0)40 730 926 -20/ -24

## 10.6 Scope of Delivery/ Accessories

Included parts	Item no.
Fastening set for wall mounting	174358

Accessories	Item no.
Splash protection (W 235 x H 385 x D 294 mm)	174360
Special spray nozzle Ø 2.5 mm	174352
Kalk-Ex, lime remover, 1000 ccm	655002

## 11 Technical Data

Wasi-Steam Classic	Item no. 174993
Voltage	220-240 V / 50/60 Hz
Power consumption	5.3 A (6.3 A medium-blowing-fuse)
Output	1220 W
Dimensions	W: 235 mm, H: 340 mm, D: 340 mm
Weight	11 kg
Working pressure	Max. 5 bar
Steam temperature	approx. 151 °C
Boiler capacity	3.3 l
Safety class	IP 22

Other voltages on request.

The noise level of the unit amounts to ≤ 70 dB (A).



Technical changes reserved.

## 12 Disposing of the Unit

The unit has to be disposed by an authorized recycling operation. The selected company has to be informed of all possibly health-hazardous residues in the unit.

### 12.1 Information on Disposal for Countries within the EU



To conserve and protect the environment, prevent environmental pollution and improve the recycling of raw materials, the European Commission adopted a directive that requires the manufacturer to accept the return of electrical and electronic units for proper disposal or recycling.

Within the European Union units with this symbol should not therefore be disposed of in unsorted domestic waste.

For more information regarding proper disposal please apply at your local authority.

**13 EU Declaration of Conformity**

in accordance with 2014/35/EU (Low Voltage Directive) and 2014/30/EU (Electromagnetic Compatibility Directive) and 2006/42/EC (Machinery Directive) and 2011/65/EU (RoHS Directive) and 2014/68/EU (Pressure Units Directive)

Manufacturer: **W A S S E R M A N N**      Product description: Steam Cleaner for  
Dental-Maschinen GmbH      dental  
Rudorffweg 15-17      applications  
21031 Hamburg  
Germany

Model: Wasi-Steam Classic      Item no. 174993

Applicable standards: DIN EN 61010-1  
DIN EN 61000-6-3  
DIN EN 61000-6-1  
DIN 45635-1  
DIN EN 60335-1

Hiermit wird bestätigt, dass die oben bezeichnete Maschine den genannten EU-Richtlinien entspricht. Diese Erklärung wird ungültig, falls die Maschine ohne unsere Zustimmung verändert wird.

This is to confirm that the above mentioned machine complies with the described EU guidelines. This declaration becomes invalid if the machine is modified without our approval.

Cette machine est conforme aux normes en vigueur d'Union européenne. Cet avis est nul et non avenant si cette machine est modifiée sans notre accord.

Esta máquina, anteriormente mencionada, cumple con los límites requeridos por el reglamento UE. Ahora bien, esta declaración quedará invalidada en caso de realizar modificaciones al aparato sin nuestra aprobación.

Hiermee wordt bevestigd dat bovengenoemde machine voldoet aan de voorgeschreven EU normen. Deze verklaring verliest geldigheid als er zonder onze uitdrukkelijke toestemming wijzigen aan de machine worden aangebracht.

Place, date: Hamburg, 2020-02-28

Company stamp :



Signature: \_\_\_\_\_

Sven Wassermann  
(Managing Director)



**WASSERMANN**  
DENTAL-MASCHINEN GMBH  
Rudorffweg 15-17 · 21031 Hamburg

Notes:





Wassermann Dental-Maschinen GmbH  
Rudorffweg 15–17 · 21031 Hamburg · Germany  
Phone: +49 (0)40 730 926-20/ -24 · Fax: +49 (0)40 730 37 24  
export@wassermann-dental.com · www.wassermann.hamburg



/WassermannDentalmaschinen