

● Automatic stand



Automatic stand
for fine blasting unit Cemat-NT



Automatic stand
for polishing compact unit WP-Ex 80

● USER MANUAL

Dear customer,

Thank you for choosing a product from the Wassermann range. Wassermann Dental-Maschinen incorporates the highest standards of quality and the latest technology.

In order to enjoy maximum performance and years of trouble-free operation, please read this user manual carefully before you connect this device and start work, and operate the device according to the recommended guidelines. The operation safety and the functionality of this device can only be guaranteed if you follow both the general safety guidelines and the applying laws to prevent accidents as well as the precautions given in this user manual. We are not liable for any damages which occur due to inappropriate usage or faulty operation of this device.



Make sure that anyone using this device has read and understood this user manual.

Keep this user manual in a safe place where it can be referred to as required at any time.

Company address:

Wassermann Dental-Maschinen GmbH

Rudorffweg 15-17

D-21031 Hamburg, Germany

Phone. : +49 (0)40 / 730 926 – 0 Fax.: +49 (0)40 / 730 37 24

E-mail: info@wassermann-dental.com

URL: <http://www.wassermann-dental.com>

Contents

1 Features.....	4
2 Safety guidelines.....	4
2.1 Safety symbols used in this manual.....	4
2.2 Safety guidelines.....	5
2.3 Responsibility for operation or damage.....	5
3 Application.....	6
4 Before starting.....	6
4.1 Transport.....	6
4.2 Installation.....	7
4.3 Storage.....	7
5 Installation / Start-up	8
6 Operation.....	9
6.1 General operating instructions.....	9
7 Troubleshooting.....	10
8 Care and maintenance.....	10
8.1 Cleaning.....	10
8.2 Maintenance.....	11
8.3 Warranty	11
8.4 Spare parts.....	11
8.5 Scope of delivery / Accessories.....	12
8.6 Repairs.....	12
9 Technical data.....	13
10 EC Conformity Certificate.....	14

1 Features

The Automatic Stand is a variable lifting table which can be adjusted by the user for individual postures to enable comfortable protracted working periods. Working is possible in sitting as well as standing position. The adjustment is done through a powerful motor and almost silent.

This stand can perfectly be used in combination with the Polishing Compact Unit WP-Ex 2000 or our Sand Blasting Unit Cemat-NT including supporting frame for a Dust-Extraction SG-1/2. but also units of other manufacturers, which do not exceed 120 kg can be placed on this Automatic Stand.

- automatic stand for ergonomically optimised working
- adjustable from 740–1090 mm
- maximum applied force of 120 kg makes it suitable for almost any equipment on the market
- motor overload protection as standard

2 Safety guidelines

2.1 Safety symbols used in this manual



Warning!

This is a warning of risk situations and dangers.

Failure to observe this warning could be life-threatening. These warnings has to be observed.



Information!

This symbol draws your attention to specific features that has to be observed.

2.2 Safety guidelines

Configuring and operating this equipment requires **precise knowledge** and **observance** of the instructions in this **user manual**. The equipment is designed only for its intended application.



WARNING:

Servicing and repairs should be carried out only by authorised specialists.
Disconnect the power plug before starting any maintenance work.



Make sure that the equipment is connected to the correct power source.



Attention! Danger of bruise!

- When moving the stand take care that you will not bruise your limbs!
- In sitting position do not cross the legs when moving down the stand!
- Do not wear shoes with thick soles!
- Do not use chairs with arm-rests!
- The stand is only allowed to be moved by the user self!

2.3 Responsibility for operation or damage

The responsibility for operating the device lies exclusively with the owner or user if said device is incorrectly serviced, maintained or altered by persons not employed by an authorised dealer or if the device is used in a manner contrary to its specified purpose.

The unit has to be maintained and operated in accordance with this user manual. Wassermann Dental-Maschinen GmbH is not responsible for damage arising from the **nonobservance** of these instructions.

Warranty and responsibility provisions contained in the sales and supply conditions of Wassermann Dental-Maschinen GmbH are not extended by these instructions.

3 Application

The Automatic Stand is a motor-driven lifting table. It enables different user to work in an ergonomic position adjusted to every ones own necessities.

The Automatic Stand is designed for our units WP-EX 2000 and Cemat NT.

But by using a special supporting frame it can also be used with other machines.

Only use the device for this type of application.

4 Before starting

4.1 Transport

Before transporting the unit, ensure that it has been unplugged from the power socket. Make sure that it is packed correctly in order to avoid accidental damage.



Be sure to check for any transport damage when unpacking the goods. Note down any damage if found.

4.2 Installation

Open the box, remove the packing materials, and carefully lift out the device and accessories. Check the included accessories.



Install the device in a place where it will not block the working area and the functionality (take the dimensions into account).

The device has to stand horizontally on a steady and even surface.

Unevenness of the bottom can be trued up through the rubber feet.; a wrench is enclosed see fig.:

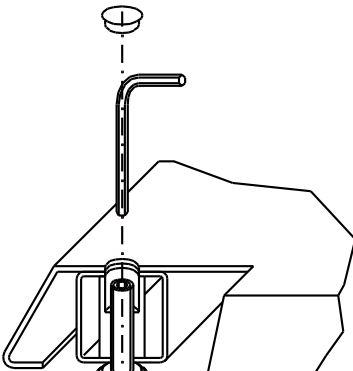

Fig.: Trueing up of unevenness of the bottom

Place the unit, e.g. the WP-EX 2000, onto the supporting frame



Do not install the unit outdoors or in places without proper ventilation.

Before start-up, be sure the device reaches room temperature.

4.3 Storage

If the unit is to be stored for an extended period, protect it from moisture and dust.

5 Installation / Start-up



Before starting the unit, connect up the following:

- Connect the unit to the connection box (power cable).
 - Insert the power plug into the socket, making sure that the mains and the unit operate on the same voltage (220-240 V / 50/60 Hz).
1. Switch on the main switch.
 2. Use the foot switch (located at the bottom of the stand foot) to move the Automatic Stand to the desired position.
 3. The Automatic Stand can be stopped and switched off in any position.
 4. Power is only supplied when the main switch is switched on.
 5. Switch off the main switch after using or finishing work.



The integrated self-locking main spindle prevents the Automatic Stand from inadvertent sagging down.



The motor of the Automatic Stand is equipped with an **overload protection** to prevent the motor from damages caused by overheating. Should the stand stop suddenly during operation, the protection switch is activated and will be reset automatically **after a few minutes cooling down**. Then the unit will function as normal.



Disconnect the power plug when not using the unit for a long period of time.



Attention! Danger of bruise!

- When moving the stand take care that you will not bruise your limbs!
- In sitting position do not cross the legs when moving down the stand!
- Do not wear shoes with thick soles!
- Do not use chairs with arm-rests!
- The stand is only allowed to be moved by the user self!

6 Operation

6.1 General operating instructions

All instructions for using the unit, whether in verbal or written form, are based on our own experience and experimentation and can only be regarded as guidelines.

1. Switch on the main switch.
2. Use the foot switch (at the bottom of the stand foot) to move the stand to the desired position.
3. Press the foot switch until the stand has reached the desired position.

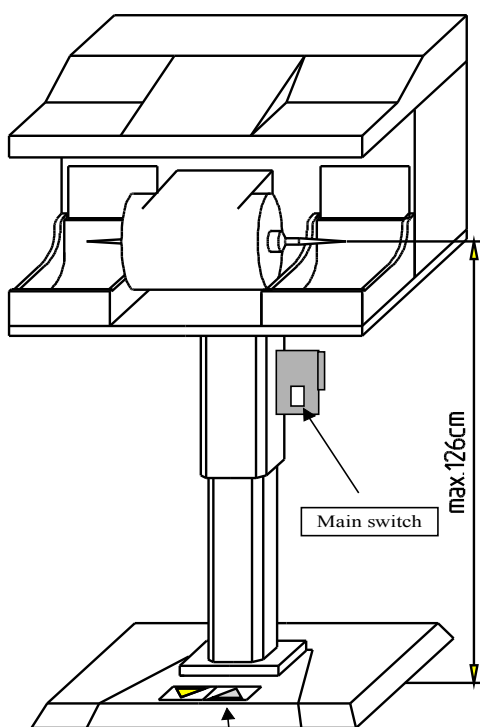

Press down the right side (arrow pointing to the front) of the foot switch!
The Automatic Stand moves up.

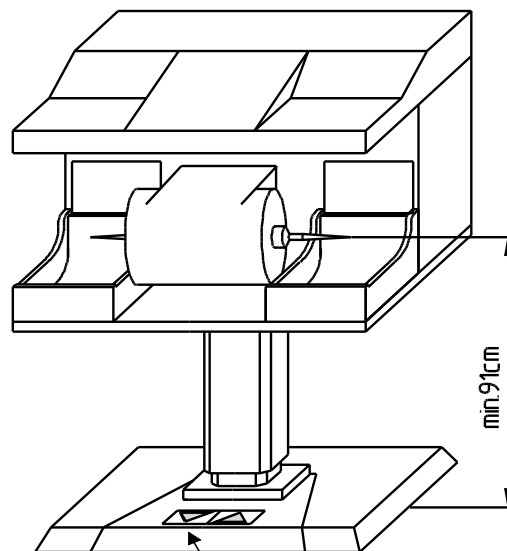

Press down the left side (arrow pointing to you) of the foot switch!
The Automatic Stand moves down.

7 Troubleshooting

Fault	Cause	Remedy
Stand position cannot be changed.	Power plug is not connected.	Check the power plug and connect it.
	Main switch is not switched on.	Check the main switch and set it to the „On“-position.
Stand stops suddenly	Motor overload protection is activated due to overheating.	Wait and let the motor cool down a few minutes. Protection switch will be reset automatically.
Stand does not start moving	Stand is overloaded	The axial load must not exceed 120 kg
	Improper application	Stand must be used for the determined purpose only.

 If the above recommendations do not solve the problem, contact your dental depot or our service department.

8 Care and maintenance

8.1 Cleaning



Disconnect the power plug before starting any maintenance work.

The identification plate has always to be kept in easily legible condition and has not to be removed.



Remove external dirt from time to time with some form of cold cleaner.

Use only cold cleaners to avoid damaging the paintwork or removing the lettering.

The equipment should be cleaned at regular intervals to ensure trouble-free operation. It requires only normal cleaning (sponge, damp cloth, mild detergent) and no further chemical additives.

8.2 Maintenance

The unit does not require any servicing. Just make sure that the device is kept clean.

8.3 Warranty



The warranty period for our equipment is 12 months. If faults occur within the warranty period, contact your dental depot or get in touch directly with our service department.

Your equipment should only be operated in perfect condition. If faults occur which could harm operators or third parties, the unit should not be used until it has been fixed.

This warranty does not cover damage caused by improper use, external mechanical causes, transport damage or interference with the unit by unauthorized persons.

8.4 Spare parts

If necessary please contact our service hotline phone:

0049 (0)40 / 730 92 6-0

8.5 Scope of delivery / Accessories

Lieferumfang:	Item-no.
Automatic stand for external devices	Item-no.: 146150
Automatic stand for WP-Ex 2000 /- Ex 3000	Item-no.: 146140
Automatic stand for Cemat-NT	Item-no.: 190420
Automatic stand for WP-Ex 80	Item-no.: 146103

Zubehör	Item-no.:
Additional drawer 630 x 90 x 555 mm (WP-Ex 2000 /-Ex 3000)	146060

8.6 Repairs



Servicing or repairs to the unit has only to be carried out by qualified technicians. Only original spare parts are to be used. Responsibility for the product is voided if unauthorised persons alter it or if inappropriate components are installed.

9 Technical data

Automatic stand for external devices	Item-no.: 146150
Automatic stand WP-Ex 2000 /- Ex 3000	Item-no.: 146140*
Automatic stand Cemat-NT	Item-no.: 190420**
Automatic stand WP-Ex 80	Item-no.: 146103***
Voltage*	220–240 V / 50 / 60 Hz
Power consumption	3.1 A
Output	660 W
W x min. H x D	630 x 740 x 540 mm
W x max. H x D	630 x 1090 540 mm
Weight	39.7 kg, 34.5 kg*, 43.8 kg**, 39.7 kg***
Stroke	350 mm
Max. load	1200 N (axial) / 120 kg
Lifting speed	ca. 20 mm / sek.

*Other voltages on request.

The noise level of the unit amounts to ≤ 70 dB (A).



The technical data are subject to change without prior notice.

10 EC Conformity Certificate

in accordance with 2006/95/EG (low-voltage guidelines) and 2004/108/EG (EMV guidelines) and 2006/42/EG (machinery guidelines)

Manufacturer:	W A S S E R M A N N Dental-Maschinen GmbH Rudorffweg 15 - 17 D-21031 Hamburg	Product description:	Electrical lifting table for an ergonomically designed laboratory work station for dental applications
Model:	Automatic stand for external devices Automatic stand for WP-Ex 2000 /- Ex 3000 Automatic stand for Cemat-NT Automatic stand for WP-Ex 80		146150 146140 190420 146103
Applicable standards:	DIN EN 61010-1 DIN EN 61000-6-3 DIN EN 61000-6-1 DIN 45635-1 DIN EN 60335-1		

Hiermit wird bestätigt, dass die oben bezeichnete Maschine den genannten EG-Richtlinien entspricht. Diese Erklärung wird ungültig, falls die Maschine ohne unsere Zustimmung verändert wird.

This is to confirm that the above mentioned machine complies with the described EC rules. This declaration becomes invalid if the machine is modified without our approval.

Cette machine est conforme aux normes en vigueur de la Communauté Européenne. Cet avis est nul et non avenant si cette machine est modifiée sans notre accord.

Esta máquina, anteriormente mencionada, cumple con los límites requeridos por el reglamento EC. Ahora bien, esta declaración quedará invalidada en caso de realizar modificaciones al aparato sin nuestra aprobación.

Hiermee wordt bevestigd dat bovengenoemde machine voldoet aan de voorgeschreven EU normen. Deze verklaring verliest geldigheid als er zonder onze uitdrukkelijke toestemming wijzigingen aan de machine worden aangebracht.

Place, date: Hamburg, 01.11.12

Company stamp:



WASSERMANN
DENTAL-MASCHINEN GMBH
Rudorffweg 15-17 · 21031 Hamburg

Signature: _____

Wilfried Wassermann
(Managing Director)

Notes:

Wassermann Dental-Maschinen GmbH
Rudorffweg 15-17 · D-21031 Hamburg
Tel.: +49 (0)40 730 926-0 · Fax: +49 (0)40 730 37 24
info@wassermann-dental.com