

Trimmer HSS-88 for Orthodontics



For Bite Orientated Trimming of Plaster Jaw Models



Wassermann Dental-Maschinen GmbH  
Rudorffweg 15-17 · 21031 Hamburg · Germany  
Phone +49 (0)40 730 926-0 · Fax: +49 (0)40 730 37 24  
info@wassermann-dental.com · www.wassermann.hamburg

# Trimmer for Orthodontics

## HSS-88 KFO

The production of jaw models belongs to the daily routine of a dental technician in the orthodontist field. Hence a simple and exact usage was the foremost thought in the construction of these accessories. When the instructions are followed step-by-step, it is possible for every technician to produce exact models. After a short trial period the working time is noticeably shorter than with the usual method.

### Laser Light Guide for Model Table:

Combination of daylight LED and laser, precise and without glare or reflections

Extra large work section of 105 x 135 mm

### Orthodontic Model Table

Manufactured using modern material combinations, designed for durability, firm bearing, almost maintenance-free

Deposit table made of stainless steel

### Our recommendation:

Use the HSS-88 with the fully diamond coated disc (Ø 260 mm) for quick model-trimming, with best and reproducible results for many years

Lockable angle stop, with application-oriented angle engraving, swivels for unrestricted freedom of movement

Convertible drain supports for easier installation even in difficult drain situations

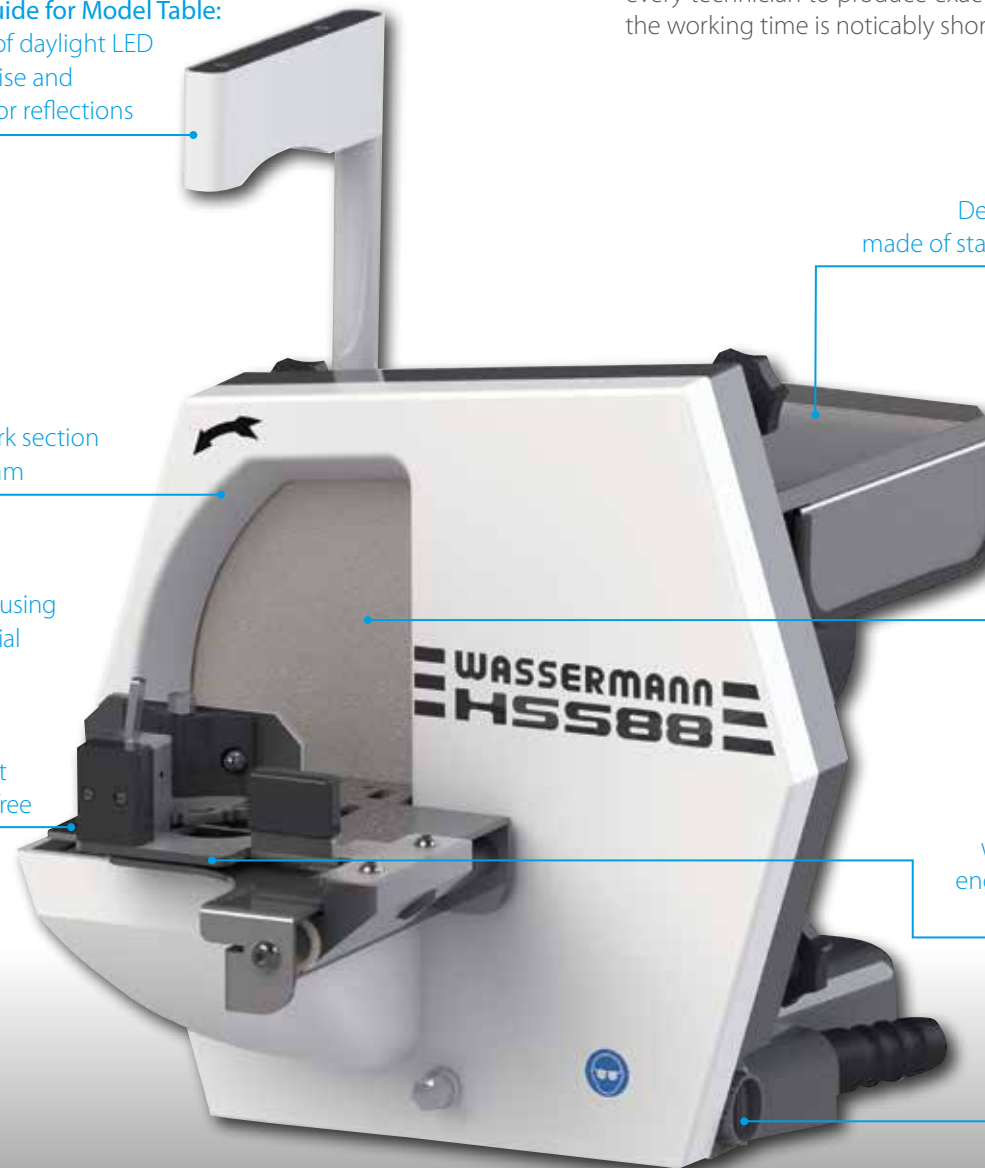

Jaw models which are precisely prepared by the dental technician give the orthodontist the basis for the necessary therapy. An orthodontist's diagnosis can only be given according to the anatomical facts of the upper and lower jaw as well as the intercusp and the intermaxilla relationship to one another. Also, demand for more notice to be taken of the facial soft parts ratio has also influenced the construction of the diagnostic models.

Because of these reasons the basic design was chosen according to Begg (Swiss and EOS version on request).

Due to various angles of the upper and lower jaw molar area there are no problems when a cross over bite exists, in the area of the vestibulums.

The diagnosis is easier because the dysgnathien is immediately noticeable. All skull levels (Fig. 1) are exactly taken into consideration. Through the chosen form of the upper and lower jaw model (Fig. 2) in the vestibular area, it is possible to reach an exact assessment of the soft parts.

The requested task, a rational and accurate method of producing plaster models is fully possible with the grinding equipment and the directional lamp which belongs to it.

The accessories for producing 3D orthodontic models are available for the trimmer HSS-99 and HSS-88. Even subsequent upgrade is possible without any problems. The orthodontic model table can be installed independently; however, due to the electrical connections, the installation of the guide light is performed by our Wassermann Service or one of our licensed specialist companies.

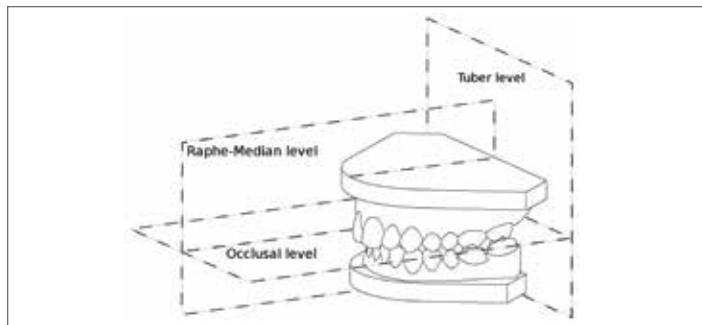

Fig. 1

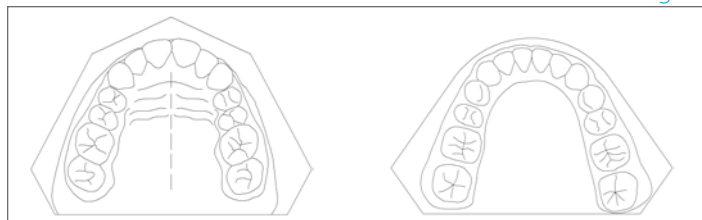

Fig. 2

### HSS-88 Basic Unit with Diamond Grinding Disc (Item no. 168998)

The HSS-88 equipped with the fully diamond coated disc makes easy work of even the hardest plaster – minimal grinding pressure, maximum time saving. Its high torque and high speed, but also energy efficient 1000 Watt motor guarantees the highest grinding speed.

### HSS-88 Model Table KMS according to Begg (Item no. 168140)

Wassermann products are known for their suitability for daily use, functionality and longevity. We also remain faithfully to this quality standard by designing the orthodontic model table.

All parts that come into contact with water are made of stainless steel. The seals are made of the latest generation of composite materials. The working surface (Fig. 3) with solid bearing is partially polished and has large slits to allow the water to flow through to avoid the models sticking during grinding.

The angle limit stop (Fig. 4) is easily pivoted away for the production of the normal plaster casts..

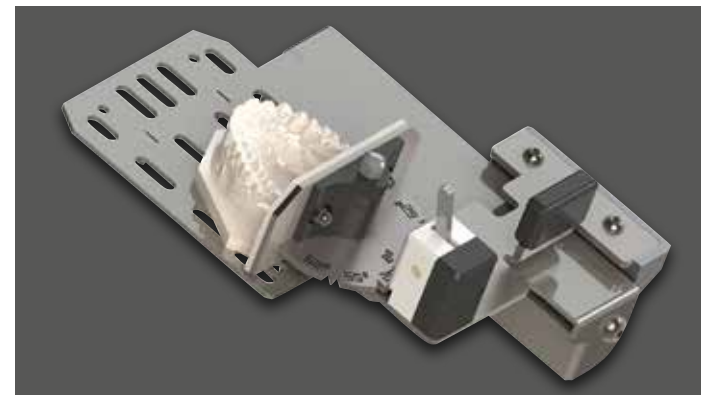

Fig. 3



Fig. 4

The limit stop for grinding the various base edges is positioned by a precise locking device (Fig. 5).

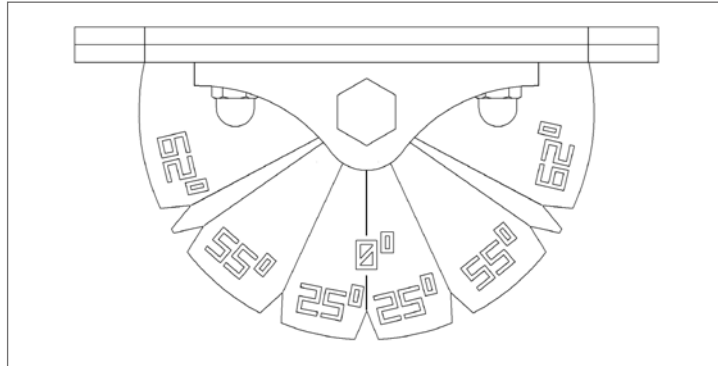

Fig. 5

#### HSS-88 Laser Light Guide for Model Table (Item no. 168120)

This innovative design is convincing: Exactly coordinated combination of daylight-LED and laser ensure unparalleled sharp contours. The laser beam is precise and not too hard at the same time. An exact line is projected on the grinding platform by the lamp, without glare or reflections. Consequently, it is possible to exactly grind the tuber level of the upper jaw by aligning the Raphe-Median-Line to the ghost line (Fig. 6). The user can adjust the guide light himself at any time.

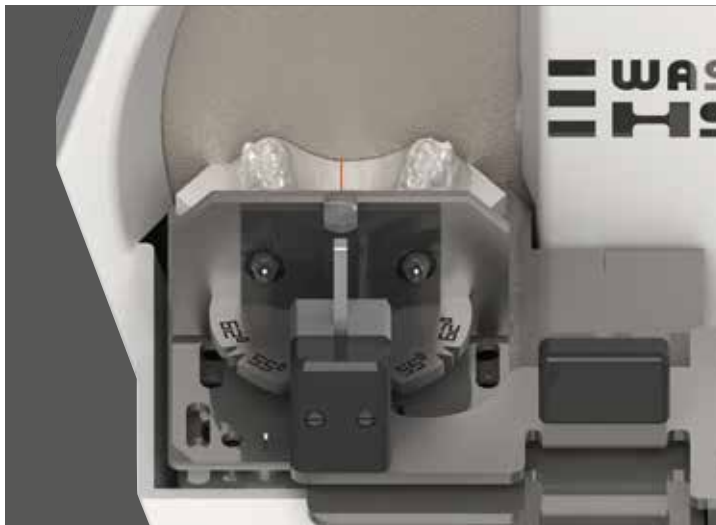

Fig. 6

#### Orthodontic Template for the Upper Jaw (Item no. 164034)

The template makes it easy to grind the combined tuber levels of the upper and lower jaws. The base form of the ground upper jaw fits exactly into the template which is then set against the angle limit stop, always exactly guided towards the grinding disc. The lower jaw laid in occlusion on the upper jaw, will thus be precisely adjusted when ground. A continual inspection of the joint tuber levels during grinding is no longer necessary (Fig. 7).

The template can also be used for very large upper jaws when the side teeth area has to be ground (Fig. 8).

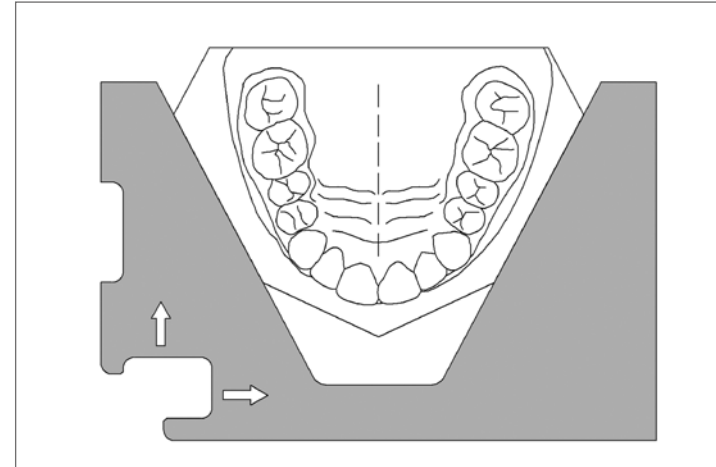

Fig. 7

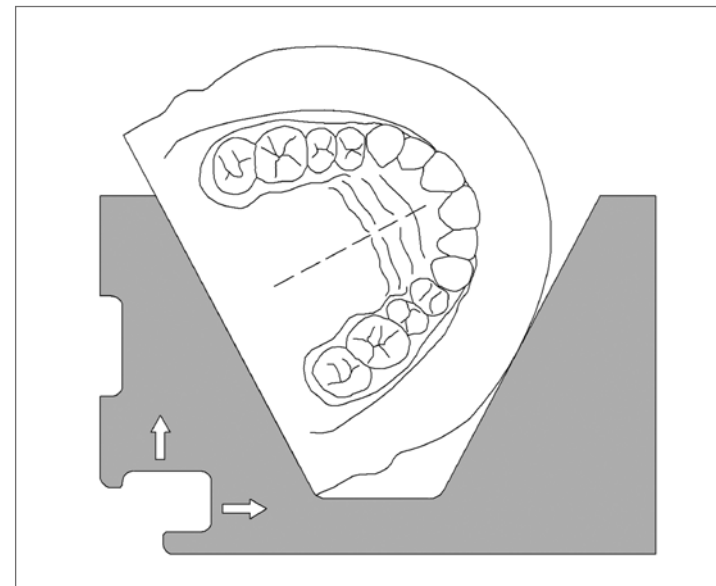

Fig. 8

## Grinding the Models

### Upper Jaw

- Lock the angle limit stop in the centre (90°).
- Lay the upper jaw model with the occlusion against the limit stop and holding it in this position (Fig. 9) push it against the trimmer disc.
- After grinding the base just a short while, the model pushes itself against the padded limit stop and it is no longer necessary to hold it.
- Remove as much as required of the base thickness.

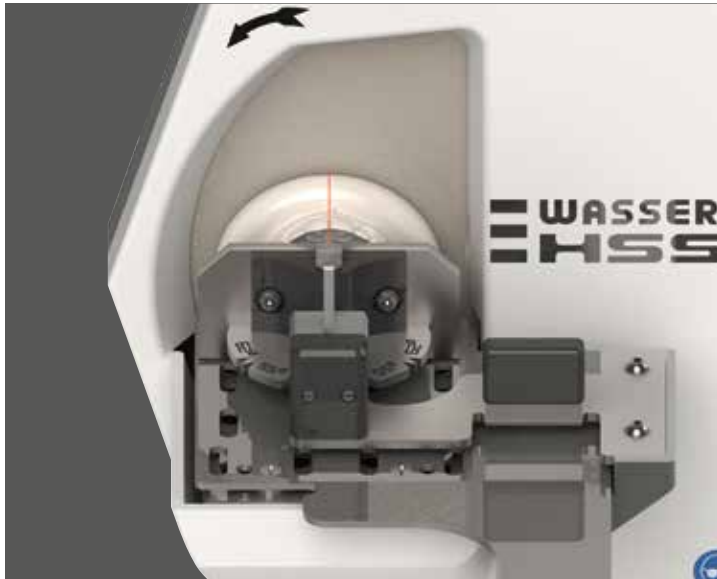

Fig. 9

- Mark the Raphe-Median-Line with a pencil and lay the model with the ground base onto the working surface. Move it towards the trimmer disc so that the ghost line and the Raphe-Median-Line mark correspond (Fig. 10). When required dorsal limit is reached the grinding process is completed.
- To grind the sides of the upper jaw turn and lock the angle limit stop in the 62° position and lay the tuber level against the limit stop (Fig. 11).
- Remove the plaster on both sides to the lowest point of the vestibule.
- Afterwards, symmetrically grind the upper jaw in the 25° position of the angle limit stop from the middle of the eye tooth towards the middle of the upper jaw (Fig. 12).
- Make the tuber level slanting by setting the angle limit stop at 90° parallel to the side teeth area (Fig. 13). The upper jaw plaster model is now completed.

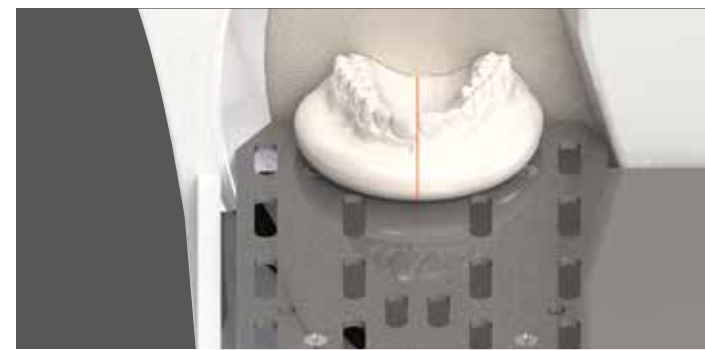

Fig. 10



Fig. 11



Fig. 12

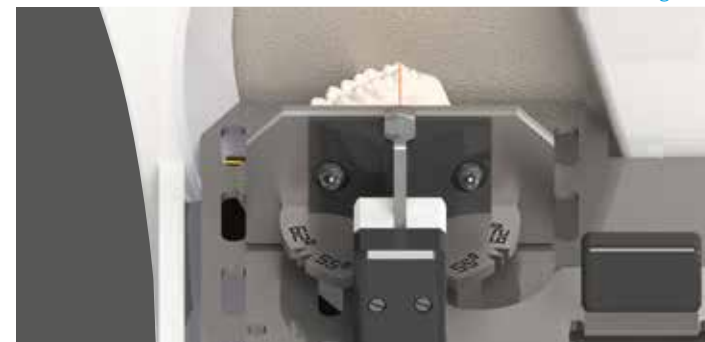

Fig. 13

### Upper Jaw / Lower Jaw

- Using the wax impression bring the lower jaw model in occlusion with the already ground upper jaw. Put the upper jaw model in the template and lay it against the 90° limit stop (Fig. 14).
- By shifting the limit stop, grind the rear side of the lower jaw model to meet the upper jaw model.
- When the joint tuber level is reached the grinding noise alters considerably.
- Lay the tuber level of both models, which are still in the occlusal position, on the grinding table and put the upper jaw base against the 90° limit stop.
- Now grind the lower jaw model down to the desired level (Fig. 15).
- The bite orientated position of the model is now reached.



Fig. 14



Fig. 15

### Lower Jaw

- In the side position, grind the lower jaw model the same as the upper jaw. However, the angle limit stop must be in the 55° position while the base must be ground according to Begg (Fig. 16).
- Grind the front area using the 90° limit stop, hence parallel to the tuber level or symmetrically rounded off to the middle 3-3 (Fig. 17).
- Again, the last operation is to make the back edge slanting, whereby the already adjusted 90° limit stop for positioning the side teeth area is used.



Fig. 16



Fig. 17

### Joint Set-up of the Upper and Lower Jaw

When both the upper and lower jaw models need to be set-up together e.g. for digital photography, it is recommended that the back edge angle is ground with the help of the template. Stand the template on its thin edge and position the side teeth area of the upper jaw against it (Fig. 18). There is enough space for the side teeth of the lower jaw which then lie in the template's cutout section.

- The grinding operation is finished when the base of the upper and lower jaw models are checked.
- All angles and edges must be symmetrical to one another.
- Eventual corrections / alterations must be done by grinding.

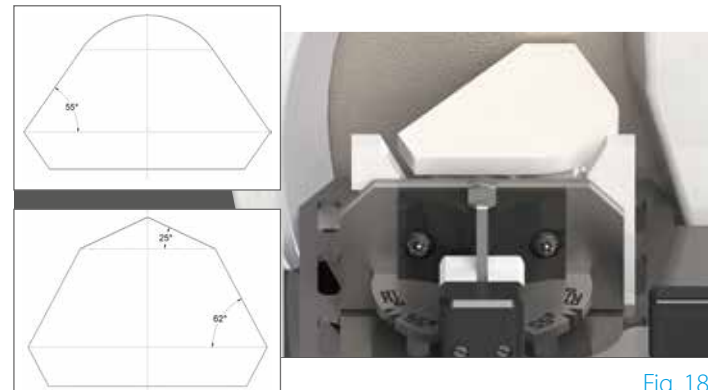

Fig. 18

Wassermann is a medium-sized, owner-operated company with head office in Hamburg. We design and produce high-quality technical devices in Germany. Our main users are dental laboratories, dental clinics and various industrial areas worldwide.

### Why a Wassermann product?

Wassermann products are manufactured from high-quality materials and the proportion of plastics used is intentionally kept as low as possible. Our devices are known for their suitability for daily use, functionality and longevity. As a result, the users place high levels of trust in the Wassermann brand. We feel it is our duty to support our customers on a daily basis when it comes to safety, service and productivity. Technological perfection, optimum quality and especially sustainability are the benchmarks we set. Thanks to the combination of these values, the family-owned company, since its establishment in 1927, has gained worldwide recognition as a manufacturer of high-quality products.



Further information are available on our website at [www.wassermann.hamburg](http://www.wassermann.hamburg)

Your Dental Dealer